

# MiCOM P746

## Numerical Busbar Protection



P746 in 80TE



### CUSTOMER BENEFITS

- Fast fault trip (typically 12 or 17 ms)
- Synchronous or Sequential trip
- Adapted to simple busbar configurations
- IEC61850-8.1 compliant
- Can operate with different types of CT
- Programmable function keys, hotkeys and tri-colour LEDs.



The MiCOM P746 centralised numerical busbar protection provides complete protection for all voltages level up to extra voltage busbar configurations.

Proven techniques, and dynamic topology processing algorithms, offer a combination of security, speed and high sensitivity.

With a typical operating time of 12 ms with HB/ HS contact option or 17 ms with standard contacts, the P746 protection is one of the fastest in its class.

Moreover, the trips can be synchronous or sequential.

Fully communicant with IEC61850-8.1, Courier, DNP3.0, Modbus and IEC103 protocols, the P746 is easily integrated in any substation system.

The substation replica processing algorithms ensure that the P746 adapts to the dynamically changing topology of the busbar which is displayed on any PC with the substation real time dynamic monitoring tool.

The MiCOM P746 differential busbar protection provides a centralised one box or three boxes architecture and is very simple to use: It does not need to be deeply engineered and supports easy operation and maintenance of the busbar.

### APPLICATION

The MiCOM P746 centralized numerical busbar protection has been designed to protect a wide range of busbar configurations:

- One box mode - P746
- Three boxes mode – one P746 per phase

In the three boxes mode, the units are totally independent and not linked to each other.

The MiCOM P746 can accommodate up to **2 Zones plus Check Zone for 1 or 3 boxes mode** and up to **4 Zones for dual 1 or 3 boxes modes**:

- 1 VT, up to 6 CTs, 6 Breakers and 12 Isolators with the One box mode solution
- 2 VTs, up to 12 CTs, 12 Breakers and 14 Isolators with the Dual One box mode solution
- 2 VTs, up to 18 CTs, 18 Breakers and 36 Isolators with the Three boxes mode solution
- 2 VTs, up to 36 CTs, 36 Breakers and 72 isolators with the Dual Three boxes mode solution.

The MiCOM P746 is associated with each CT location, usually one per incomer/feeder and one or two for each bus coupler/bus section. The MiCOM P746 acquires the analogue signals from the associated CT and the binary signals from the auxiliary contacts of the circuit breakers and isolators.

The MiCOM P746 also incorporates the main circuit breaker failure logic together with additional protection functions (Dead zone, overcurrent, etc...). The P746 particularly useful in double busbar applications allows high number of opto inputs (up to 40) and relay outputs (up to 32), function keys and Ethernet or second rear port board option.

Topology scheme examples

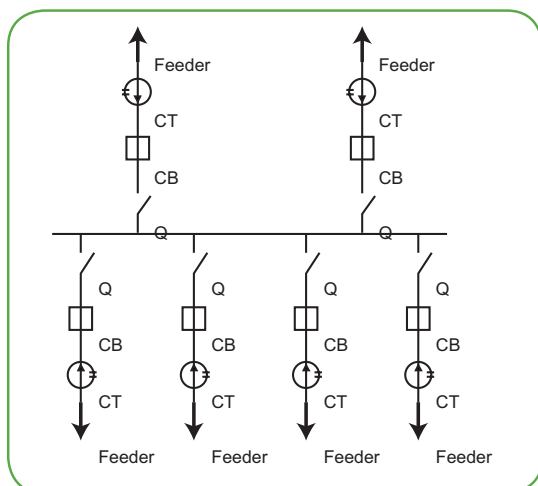
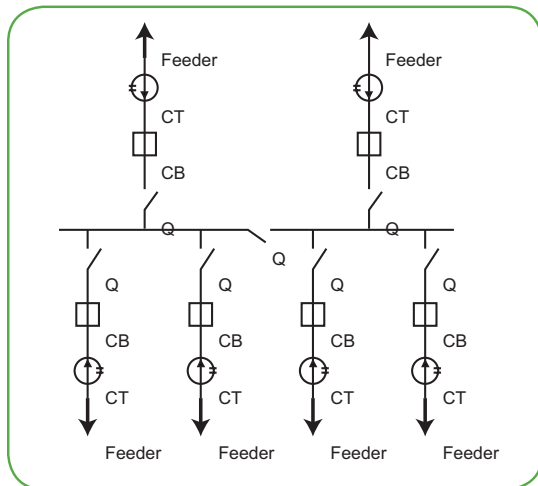
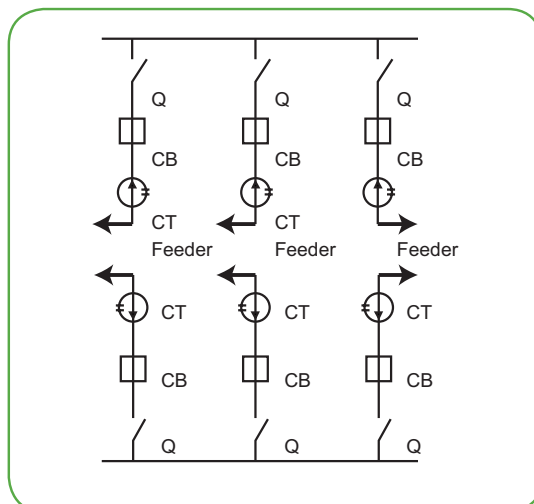
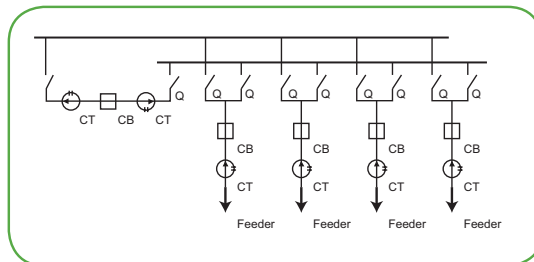
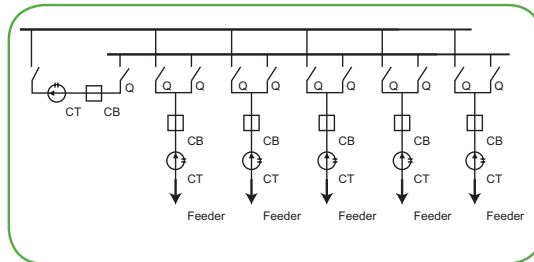
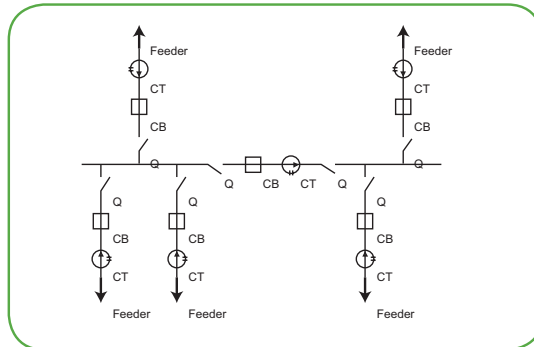
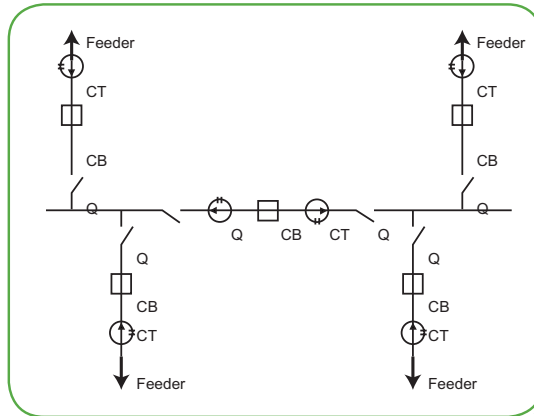

Cost optimised  
to suit simple busbar  
configuration



ANSI	IEC 61850	FEATURES	P746
87BB / P	PhsPDIF	Phase segregated biased current differential high speed busbar protection	•
87CZ / P	CzPPDIF	Check Zone segregated biased phase current differential high speed busbar protection	•
50/51/P	OcpPTOC	Phase overcurrent protection (2 stages)	•
50/51/N	EfmPTOC	Earth overcurrent protection (2 stages)	•
50ST / P	DzpPhsPTOC	Dead zone phase protection (short zone between CTs and open CBs)	•
50ST / N	DzpEfmPTOC	Dead zone earth protection (short zone between CTs and open CBs)	•
CTS		Current transformer supervision	•
VTS		Voltage transformer supervision	•
50BF	RBRF	Breaker failure protection (LBB)	•
		ISL Isolator discrepancy alarm	•
	OptGGIO	Digital inputs	16 to 40*
	RlyGGIO	Output relays	16 to 32*
		Front communication port (RS232)	•
		Rear communication port (Kbus/EIA(RS)485)	•
		Second Rear communication port (Kbus/EIA(RS)485) *	Option
		Rear communication port (Ethernet) *	Option
		Time synchronisation port (IRIG-B) *	Option
	FnkGGIO	Function keys	10
	LedGGIO	Programmable tri-colour LEDs	18

\* Refer data sheet for model selection

### Functional Overview

(Description of ANSI code nos., see Protection Function Overview)

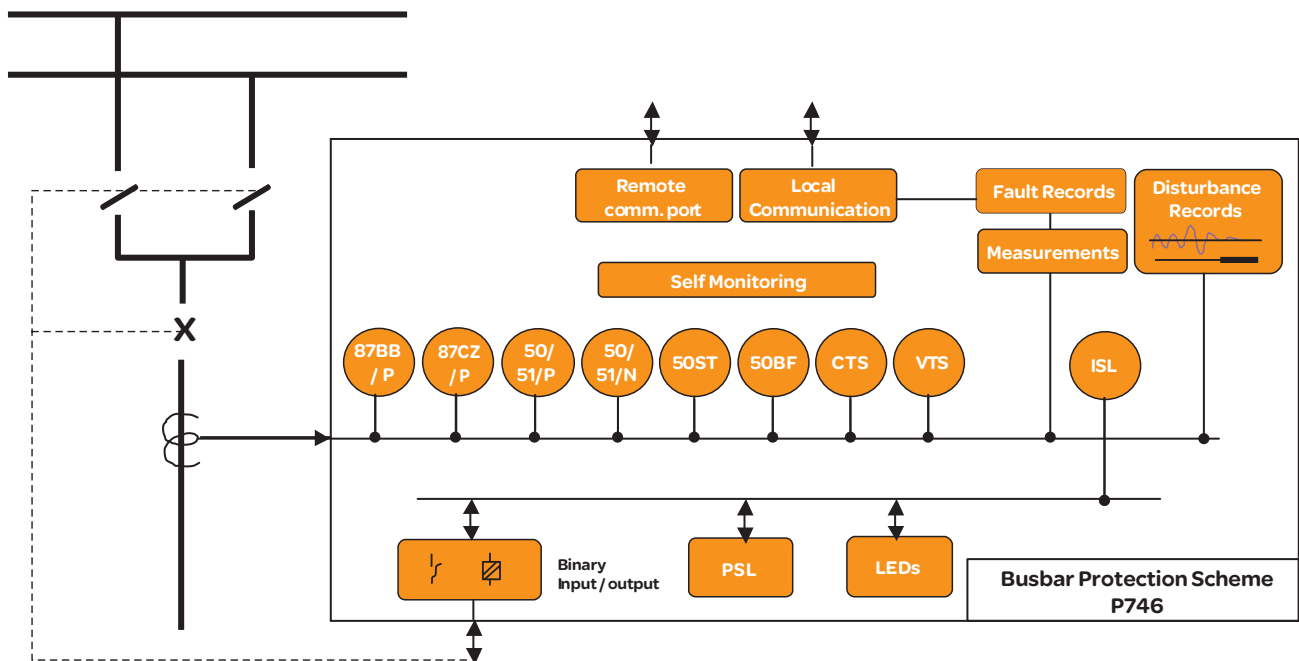

### MANAGEMENT FUNCTIONS

In addition to the protection and control elements, the P746 provides a wide range of measurement, monitoring, post fault analysis and self-diagnostic features:

- Trip circuit supervision (using PSL)
- On-line measurement
- Plant status monitoring
- 4 alternative setting groups
- Programmable logic (PSL)
- Sequence of event recording (SOE)
- Comprehensive Fault record
- Comprehensive disturbance recording (waveform capture)
- User configurable function keys & hotkeys
- User configurable tri-colour LEDs
- Local and remote communication ports
- Time synchronisation
- Fully customisable menu texts
- Multi level password protection
- Test facilities
- Power-up diagnostics and continuous self-monitoring of relay.
- User friendly setting, analysis and monitoring software

### BUSBAR DIFFERENTIAL PROTECTION

The primary protection element of the P746 is the phase segregated biased current differential protection. The technique is based on the numerical application of Kirchoff's Law for the selective detection and high-speed isolation of a faulty section of the busbar.

To ensure adaptability of the relay to any type of busbar configuration the P746 is built with a universal topology processing algorithm. This algorithm determines the optimum tripping zone based on the current status of the plant isolators or/and circuit breakers.

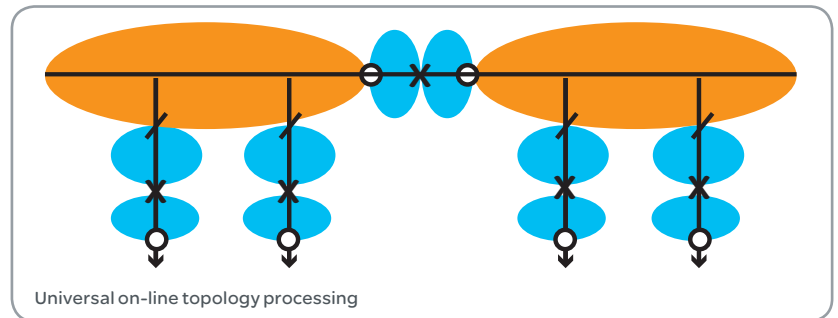

The P746 employs biased differential algorithms, in which the differential current is compared with a bias current. This characteristic ensures stability of the protection for external faults even with differing CT tolerance and errors which could lead to spurious operation.

To increase the security of the differential protection, the biased differential element is supervised by a biased global Check Zone element. This ensures stability even under erroneous status of the auxiliary contact of plant isolators and circuit breakers.

The MiCOM P746 also employs CT supervision and an innovative external fault detection algorithm: the current phase comparison. This ensures stability when CTs become saturated. This technique is heavy CT saturation proof and still trip on evolving to internal fault..

Bias differential characteristics

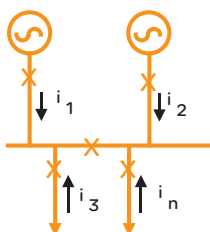
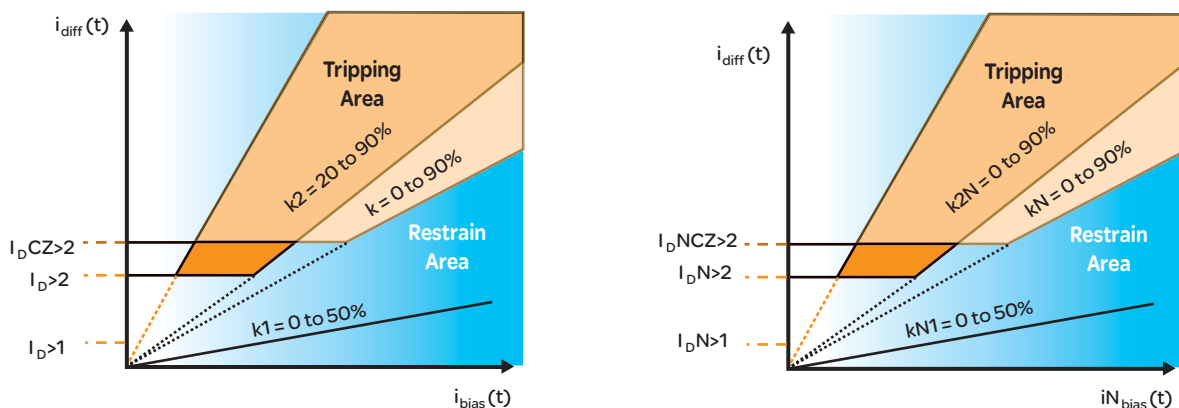

Differential current :  $i_{diff\ node}(t) = i_1 + i_2 + i_3 + \dots + i_n$

Operating current :  $i_{diff}(t) = |i_{diff\ node}(t)| = |\sum i_i|$

Bias current :  $i_{bias}(t) = |i_1| + |i_2| + |i_3| + \dots + |i_n| = \sum |i_n|$

### MULTIPLE TRIPPING CRITERIA

The MiCOM P746 maintains the highest level of stability under all conditions including hardware failure and incoherent signals applied from external plant or generated by the power system.

Any tripping order must therefore be made conditional on the simultaneous occurrence of at least 5 criteria:

#### Magnitude Criteria: Confirmation of Two Simultaneous Thresholds per Zone:

- Exceeding the bias slope characteristic ( $k_2$ )
- Exceeding differential operating current threshold ( $I_D > 2$ ).

#### Check Zone Supervision

The zone element(s) are only permitted to trip if the order is confirmed by the check zone element:

- Exceeding the bias slope characteristic ( $k_{CZ}$ )
- Exceeding differential operating current threshold ( $I_{DCZ} > 2$ )

#### Current Phase Comparison Criteria

##### Optional Voltage Criteria:

- Undervoltage  $U < OR$ ,  $V_1 < OR$
- Negative sequence overvoltage  $V_2 > OR$
- Zero sequence overvoltage  $3V_0 >$

### SYNCHRONOUS OR SEQUENTIAL TRIPPING

The MiCOM P746 allows delaying all or each tripping contact.

That is highly recommended for high speed disconnection of the bar from grid and delayed trip of the generation feeders

### DEAD ZONE OR BLIND SPOT PROTECTION

The current transformers or the open isolators surrounding the busbars define the limits of the main zones. When a feeder isolator is opened a dead zone or blind spot is created to the associated CT. The MiCOM P746 detects this condition automatically and provides protection for this zone also.

One stage of definite time delayed overcurrent and earth fault protection is provided in each Peripheral Unit to provide this functionality.

### CONTINUOUS SUPERVISION OF CURRENT CIRCUITS

The P746 detects any abnormality in the current circuit by continuously monitoring it. Under normal operating conditions the differential current will be negligible. An anomaly is detected by a threshold,  $I_D > 1$ , which can be set to alarm from 10 A primary.

### CONTINUOUS SUPERVISION OF CURRENT TRANSFORMERS

The P746 detects abnormality in any current transformer by continuously supervising them.

### DIFFERENTIAL CURRENT SETTING

When switching operations are carried out in the substation, incorrect topology replicas may occur.

In this case, a differential current appears. The differential elements of the MiCOM P746 are allowed to operate only if the differential current reaches a threshold  $I_D > 2$  which is normally set above the highest load current when no voltage criteria is used.

### PHASE OVERCURRENT AND EARTH FAULT PROTECTION

Two independent stages of phase overcurrents and earth fault protection are provided in the MiCOM P746. These elements provide additional protection for the individual circuits. The two stages can be programmed as:

- First stage can be programmed as definite time (DT) delay or one of the nine inverse time (IDMT) curves (IEC/UK and IEEE/US).
- Second stage can only be programmed as definite time.

### CIRCUIT BREAKER FAILURE PROTECTION (LBB)

The P746 offers an in-built integrated solution for breaker failure protection.

In general the Breaker Failure protection is executed on a per phase basis which involves the possibility of receiving tripping orders on a per pole basis.

The MiCOM P746 busbar protection can also work in co-ordination with external breaker failure protection relays. In this configuration, the receipt of an external breaker failure command results in tripping of all the adjacent circuit breakers, via the topological recognition system knowing which breaker is connected to which zone.

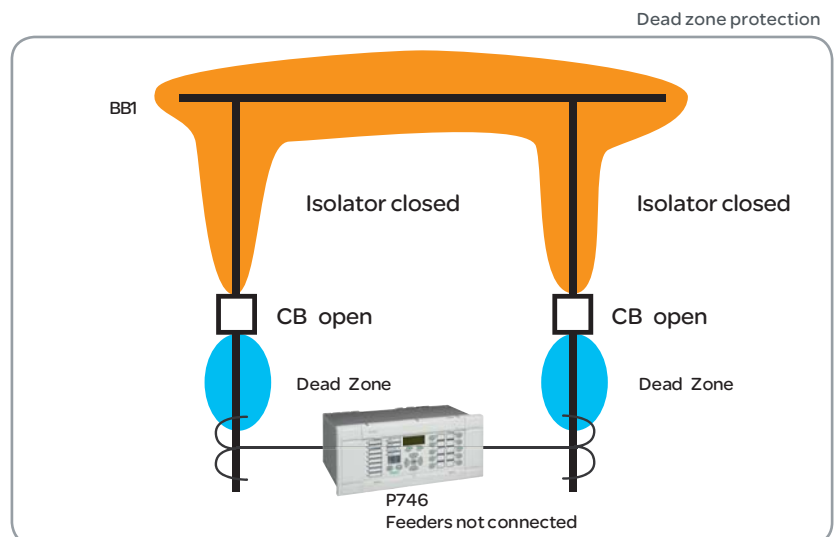

### CURRENT TRANSFORMER MIXING CORRECTION

The MiCOM P746 can correct a mix between current transformer ratios over a very wide range up to 20. Its associated user interface provides a range between 1 A and 30 000 A primary.

Since the current transformer ratings in a substation may be of mixed ratios, the MiCOM P746 uses a virtual CT ratio equal to a settable reference current/1, irrespective of the feeder section concerned.

### ISOLATION AND MAINTENANCE OPERATING MODE

For ease of operation or maintenance of the busbar protection system, the MiCOM P746 can receive specific commands designed to allow system testing or other intervention without any danger of unwanted tripping.

In the MiCOM P746, a centralised command to isolate the busbars can be selectively applied per zone:

- Differential protection (87BB) and Circuit Breaker Failure protection (50BF) blocked. The additional local protection functions (51, 51N, etc...) remain operational.

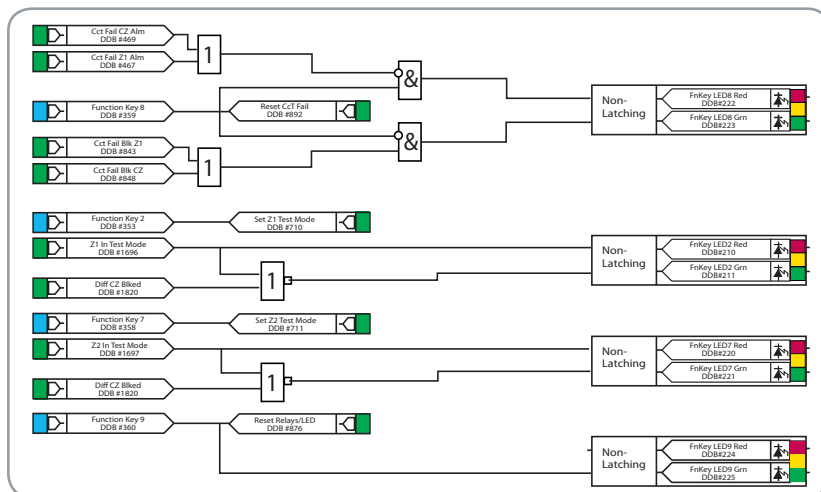

Programmable scheme logic (MiCOM S1 Studio- PSL Editor)

### PROGRAMMABLE SCHEME LOGIC

Powerful programmable logic (PSL) allows the user to customize the protection and control functions. It is also used to programme the functionality of the optically isolated inputs, relay outputs and tri-colour LED indications. The programmable logic comprises of gate logic and general purpose timers. The gate logic includes OR, AND and majority gate functions, with the ability to invert the inputs and outputs, and provide feedback. The programmable logic is configured using the graphical MiCOM S1 Studio PC based support software

### PLANT STATUS

Checks and monitoring of the plant status can be made and an alarm raised for any discrepancy condition between the open and closed auxiliary contacts of the isolators and circuit breakers.

### REMOTE HMI

The real time Remote HMI software allows the user to monitor the position of CBs and isolators in the busbar scheme, as well as currents, alarms, etc...

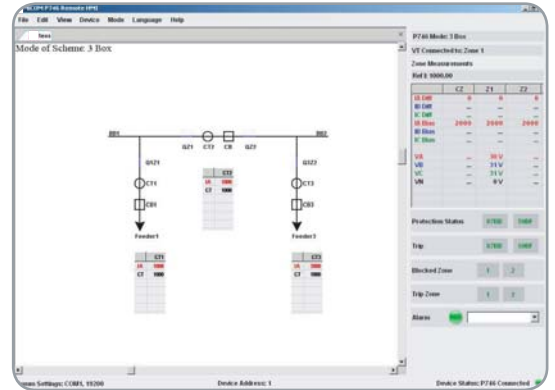

Remote HMI

### MEASUREMENT AND RECORDING FACILITIES

The P746 is capable of measuring and storing the values associated with a fault. All the events, faults records and disturbance records are time tagged to 1 ms using an internal real time clock. An optional IRIG-B port is also provided for accurate time synchronisation. A lithium battery provides a back up for the real time clock and all records in the event of supply failure.

### MEASUREMENTS

The measurements provided, which may be viewed in primary or secondary values, can be accessed via the back lit liquid crystal display. They are also accessible via the communication ports. The following instantaneous parameters can be viewed:

#### MiCOM P746

- Phase current magnitude IA and/or IB and/or IC
- Phase current angle IA and/or IB and/or IC
- Voltage magnitude and angle
- Frequency
- Differential current Idiff / phase / zone
- Bias current Ibias / phase / zone
- Check zone Idiff / phase
- Check zone Ibias / phase

### EVENT RECORDER

Up to 512 time tagged event records are stored in battery backed memory, and can be extracted via the communication port or be viewed on the front panel display.

### FAULT RECORDER

Records of the last 5 faults are stored in the battery backed memory.

Each fault record includes:

- Faulted phase
- Indication of the faulty zone
- Date and time
- Active setting group
- Fault duration
- Currents, frequency and voltage

### DISTURBANCE RECORDER

The MiCOM P746 has independent disturbance recording facility. It can record 18 analogue and 32 digital channels in addition to 1 time channel.

- Specific analogue channels
- VAN, VBN and VCN
- IA, IB, IC for each CT in 1 box mode
- I<sup>x</sup>1 to I<sup>x</sup>18 (x is A or B or C) in 3 box mode
- Maximum duration of one record and number of records
- Up to 10.5s per record and minimum of 50 records 1.5s (memory of 75s)

Disturbance records can be extracted from the relay via the remote communications and saved in the COMTRADE format. These records may be examined using MiCOM S1 Studio or any other standard COMTRADE viewer.

Disturbance record viewed in MiCOM S1 Studio

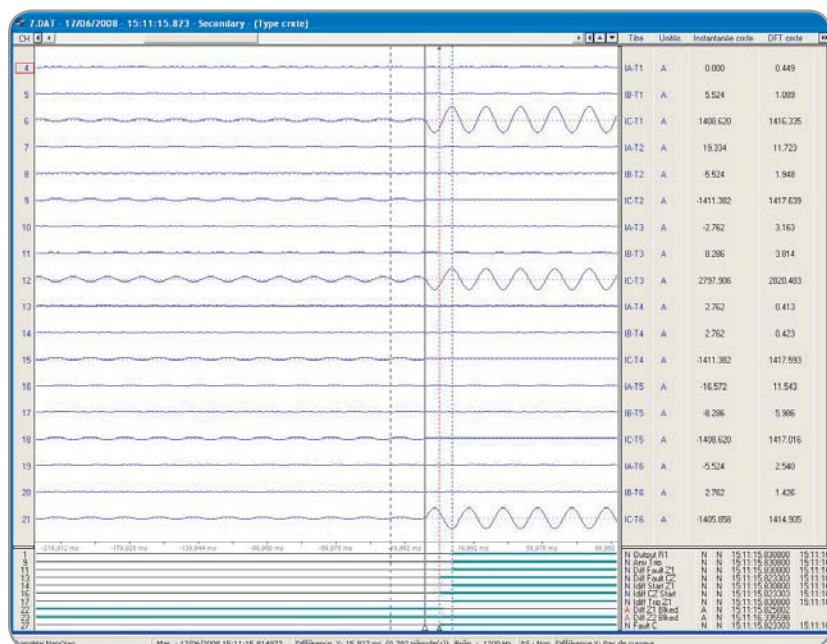

### LOCAL AND REMOTE COMMUNICATIONS

Two communication ports are available as standard; a rear port providing remote communications and a front port providing local communications.

As option either a second rear port or an Ethernet board (to use the IEC61850-8.1 protocol) can be added .

The front RS232 port has been designed for use with MiCOM S1 Studio, which fully supports functions within the relay by providing the ability to programme the settings off-line, configure the programmable logic, extract and view event, disturbance and fault records, view the measurement information dynamically and perform control functions (using Courier protocol).

The default remote communications is Courier / RS 485 or K-bus but IEC60870-5-103 or Modbus or DNP 3.0 can be selected.

An optional second rear courier communications port is available which may be configured as RS232, RS485 or K-Bus. IEC 61850 is available when the optional Ethernet port is ordered. IEC 61850-8.1 offers high-speed data exchange, peer-to-peer communication, reporting, disturbance record extraction and time synchronisation.

### DIAGNOSTICS

Automatic tests performed including power-on diagnostics and continuous self-monitoring ensures a high degree of reliability. The results of the self-test functions are stored in battery backed memory. Test features available on the user interface provide examination of input quantities, states of the digital inputs and relay outputs. A local monitor port provides digital outputs, selected from a prescribed list of signals, including the status of protection elements.



Fast, Sensitive & Secure:  
P746 the Centralised Solution  
for Busbar Protection

**HARDWARE**

The MiCOM P746 includes:

- A back-lit liquid crystal display
- LEDs: 18 tri-color
- Function keys
- Hotkeys
- RS232 (front port) & RS485 / K-bus (rear port)
- Optional Ethernet rear communication board or
- Optional Second rear communication board
- Optional IRIG-B port
- Download/monitor port
- Battery (supervised)
- N/O and C/O watchdog contacts
- Supervised +48 V field voltage
- CT inputs 1A and 5A
- Universal opto inputs with programmable voltage threshold

The optically isolated inputs are independent and may be powered from the +48V field voltage.



**DEVICE TRACK RECORD**

- Over 200 **DIFB**, medium impedance biased differential busbar protection scheme delivered since its launch in 1992.
- Medium impedance biased differential busbar protection with linear current combination, **DIFB CL**, launched in 1996. Over 70 cubicles delivered.
- Since the launch of the **P740**, over 800 systems have been delivered
- Since the launch of the **P746**, over 350 relays have been delivered.



**Schneider Electric Industries SAS**

35, rue Joseph Monier  
 CS 30323  
 F - 92506 Rueil Malmaison Cedex (France)  
 Tel.: +33 (0) 1 41 29 70 00  
 RCS Nanterre 954 503 439  
 Capital social 896 313 776 €  
 www.schneider-electric.com

As standards, specifications and designs change from time to time, please ask for confirmation of the information given in this publication.

Design: Schneider Electric Industries SAS - Sonovision  
 Photos: Schneider Electric Industries SAS  
 Printed: Altavia Connexion - Made in France

