

# MiCOM P441, P442 & P444

## Full Scheme Distance Relay



MiCOM P441, P442 & P444 numerical full scheme distance relays provide flexible, reliable, protection, control and monitoring of transmission lines.

The MiCOM distance protection relays can be applied for a wide range of overhead lines and underground cables in high voltage systems.

Based on a patented, proven algorithm with more than 2 decades of established field experience, the P441, P442 & P444 relays provide an unparalleled combination of speed, security and selectivity for any kind of power system fault.

The wide range of communication options help in easily connecting the relay to any type of Digital Control System or SCADA.

The optional redundant Ethernet board (P442/P444 only) reduces the cost of ownership since the relay is natively embedded with the switch board. This reduces the amount of stand alone switches needed, reducing the wiring, power supply and maintenance costs. Furthermore, increasing the availability rate decreases the risk of electric outages.

### APPLICATION

MiCOM P441, P442 and P444 Numerical Full Scheme Distance Relays provide comprehensive distance protection for different applications like: lines, cables, tapped lines, lines with multiple zero sequence sources, non-homogeneous lines, series compensated lines and parallel lines.

The independently settable resistive reach for each zone allows easy application to short lines and cable protection. Using well-proven, patented techniques to directionalise, and making full use of digital memory, the relays can be applied in situations that can cause classic distance implementations to maloperate (cross-country faults, close-up faults, etc.).

The MiCOM P441, P442 and P444 are in-built with a library of channel aided scheme logic, supplementary and back-up protection. It provides complete protection (4 alternative setting groups) to solidly earthed systems from distribution to transmission voltage levels.

Three phase tripping with faulted phase indication is provided for all protection functions. In addition models P442 and P444 allow single-phase tripping for the distance protection and the channel aided DEF protection (67N).

The P441, P442 and P444 distance relays equipped with 150MHz CPU and coprocessor board have been enhanced as described in the Protection Functions Overview table.



### CUSTOMER BENEFITS

- Dual Algorithms
- Polygonal characteristic (quadrilateral)
- Fastest operating time: 0.85 cycles
- Wide choice of channel aided schemes
- Powerswing detection / Out of Step protection
- Inter relay protection communication
- Option of multiple communication protocols and interfaces, including IEC61850-8-1 (Station Bus)
- Process Bus Ready
- User customizable by graphical tools

PROTECTION FUNCTIONS OVERVIEW

ANSI	IEC61850	FEATURES	P441	P442	P444
21P	PDIS	Quadrilateral Full scheme phase distance protection (5 zones)	•	•	•
21G	PDIS	Quadrilateral Full scheme ground distance protection (5 zones)	•	•	•
50/51/67	OcpPTOC / RDIR	Directional / non-directional phase overcurrent (4 stages)	•	•	•
50N/51N/67N	EfdPTOC / RDIR	Directional / non-directional stand by earth fault (2 stages)	•	•	•
67N	EfaPSCH	Channel aided directional earth fault protection (DEF)	•	•	•
32N		Directional zero sequence power protection	•	•	•
67/46	NgcPTOC / RDIR	Directional / non-directional negative sequence overcurrent	•	•	•
68	RPSB	Power swing blocking & Out of step tripping (using PSL)	•	•	•
50/27	PSOF	Switch on to fault / trip on reclose (SOTF/TOR)	•	•	•
85	PSCH	Channel aided schemes (PUTT, POTT, Blocking)	•	•	•
		Weak infeed echo logic	•	•	•
		Accelerated trip feature: Loss of Load -Zx extension	•	•	•
49	PTTR	Thermal overload protection	•	•	•
	PTRC	Tripping	3p	1/3p	1/3p
79	RREC	Auto reclose (4 shots)	3p	1/3p	1/3p
25	RSYN	Check synchronising	option	option	option
27	PTUV	Under voltage (2 stage)	•	•	•
59	PTOV	Over voltage (2 Stage)	•	•	•
37		3 Phase undercurrent		•	•
81U/O		Under/Over frequency		•	•
46BC		Broken conductor (open jumper)	•	•	•
50ST	OcpPTOC	Stub bus protection	•	•	•
50BF	RBRF	Circuit breaker failure	•	•	•
VTS		Voltage transformer supervision (1, 2 & 3 phase fuse failure detection)	•	•	•
CVTS		Capacitive voltage transformer supervision	•	•	•
CTS		Current transformer supervision	•	•	•
51FF	PTOC	Emergency overcurrent on VT failure	•	•	•
	OptGGIO	Digital inputs	8	16	24
	RlyGGIO	Output relays (fast output optional)	14	21	32 or 46
	SV	IEC61850-9-2 sampled values			•
		Front communication port (RS232/K-Bus)	•	•	•
		Rear communication port (RS485/Optic/Ethernet) * Second rear communication port (RS232/RS485/K-Bus) *	NA	option	option
		Time synchronisation port (IRIG-B) *	NA	option	option

\* It may not be possible to get all in one particular model, refer data sheet for model selection

NA: Not Applicable

### Functional Overview

- Description of ANSI code nos., see Protection Function Overview
- Description of Local and Remote Communication see page 7

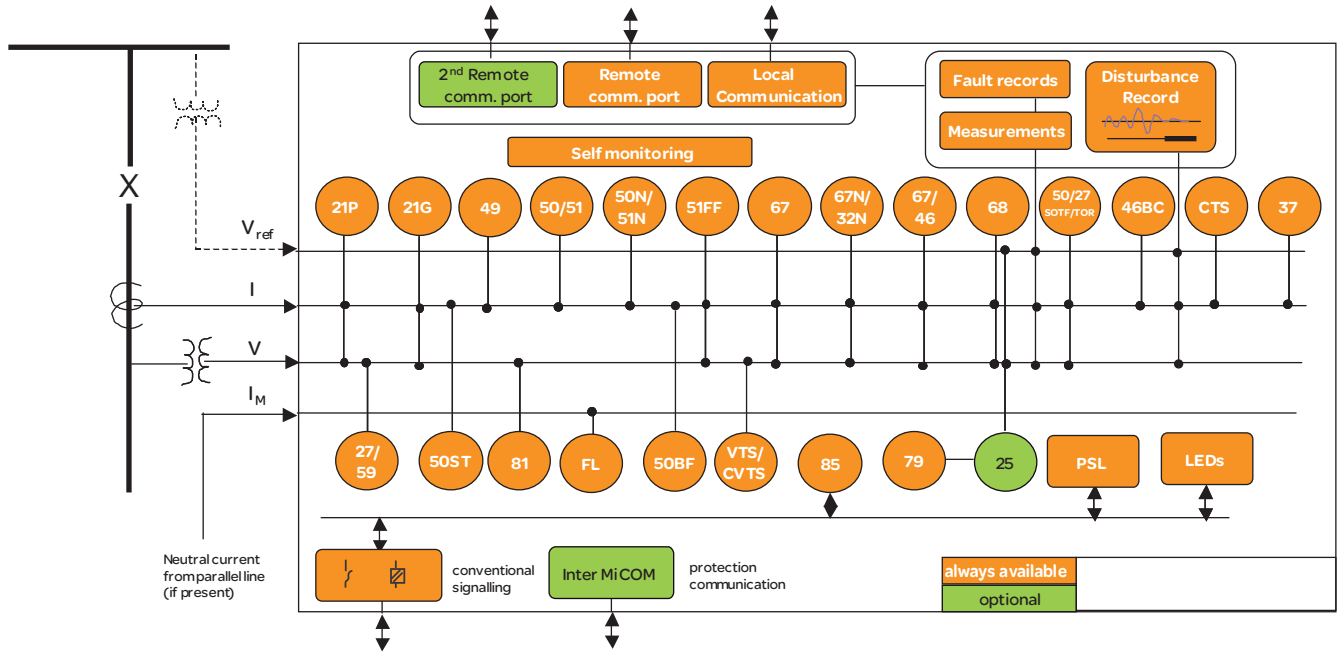

### MANAGEMENT FUNCTIONS

To complement the wide range of protection functions listed in the table, the P441, P442 and P444 relays are provided with the following measurement, control, monitoring, post fault analysis and self-diagnostic functions.

- Fault locator
- Display of instantaneous measured and derived values
- Circuit breaker control, status & condition monitoring.
- Trip circuit and coil supervision
- 4 alternative setting groups
- Programmable scheme logic
- Programmable allocation of digital inputs and outputs
- Sequence of event recording
- Comprehensive disturbance recording (waveform capture)
- User configurable LEDs

- Local and remote communication ports
- Multiple communication protocol and interface options
- Time synchronisation
- Fully customisable menu texts
- Multi level password protection
- Test facilities
- Power-up diagnostics and continuous self monitoring of the relay
- User friendly setting and analysis software (MiCOM S1 Studio)



**MiCOM P440:**  
Wide range of features to suit protection needs for all types of application

### DISTANCE PROTECTION

The operation of the distance relay is based on the combined use of two fault detection algorithms:

- Calculation of the superimposed current and voltage values that are characteristic of the fault (“Delta” algorithms).
- Measurement of impedance values (“Conventional” algorithms).

This dual algorithm offers reliable detection of all types of faults in the network. The impedance calculations are performed every sample for all six loops AN, BN, CN, AB, BC and CA, making this a true full scheme numerical distance relay.

Based on transient components, the delta algorithm is a patented technique with nearly two decades of experience in various relays. The delta algorithm uses the superimposed signals, which appear during faults, for fault detection, phase selection and direction determination. The directional element uses the sign of the energy calculated from  $\Delta V$  and  $\Delta I$  to decide the direction of the fault

- for a forward fault  $\Delta V$  and  $\Delta I$  are of opposite polarity (sign of energy: negative) and
- for a reverse fault  $\Delta V$  and  $\Delta I$  are of the same polarity (sign of energy: positive).

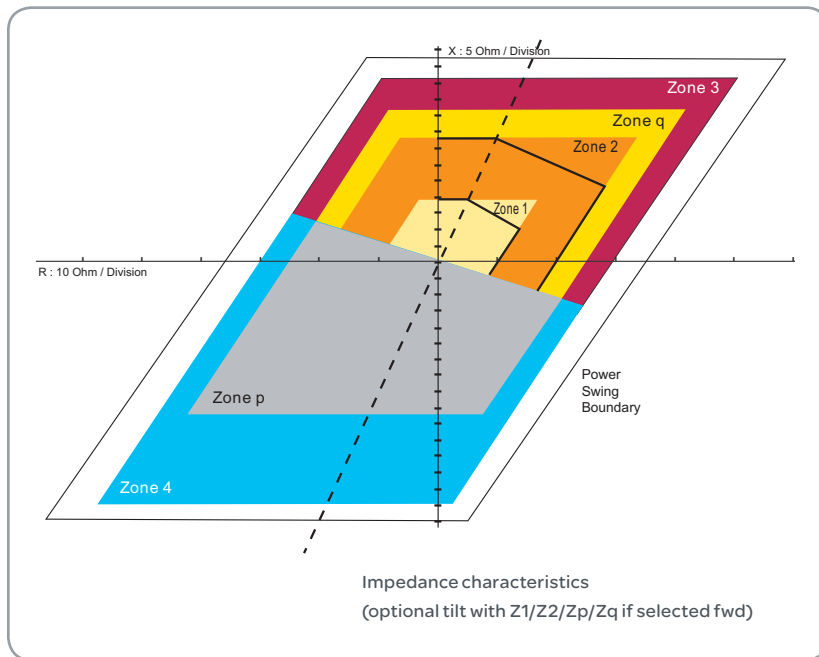

The directional and phase selection elements will change their decision if required, for example during evolving faults.

Conventional algorithm: uses the impedance measurement criteria with quadrilateral-shaped characteristics. Phase selection is enhanced for high current faults by utilising current phase selection. If the fault current is low, impedance based phase selection is used.

Both algorithms work in parallel, independently monitoring the system, measuring the impedance loops and calculating delta values continuously. From B1.0 version, the distance algorithm chaining has been optimized to ensure a typical time of 1 - 1.1 cycle for any type of fault and SIR (from 1 to 30).

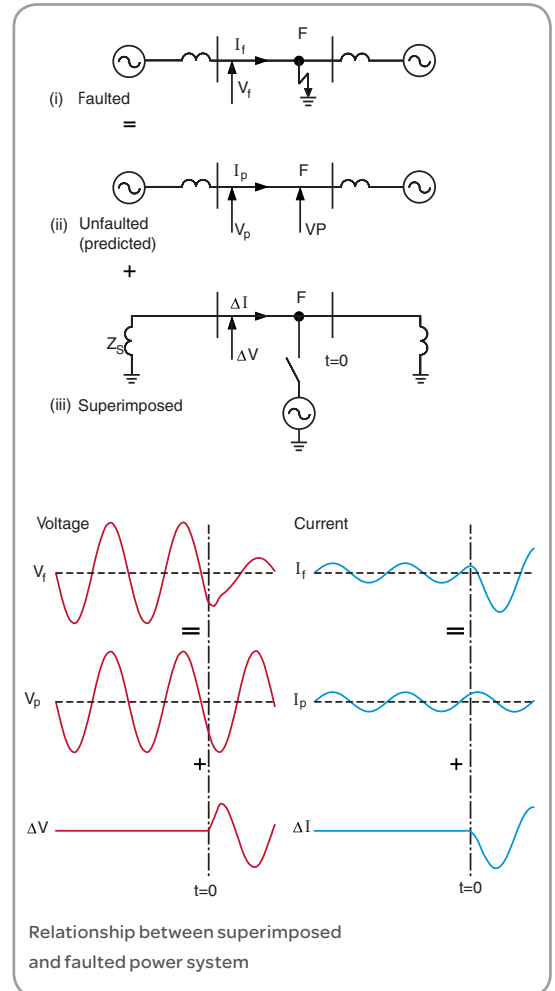

Six independently settable quadrilateral zones, each for phase faults and earth faults are provided. Four independent earth fault residual compensation coefficients are provided for nonhomogeneous line protection, or the back-up protection of transformers.

Zp and Zq can be selected forward or reverse.

The distance to fault measurement is immune to fault resistance and load current. A least squares method is used to get the algorithms to converge rapidly.

**MiCOM P440:**  
Designed for secure  
protection of your system

### POWER SWING BLOCKING

A power swing is detected when the impedance locus takes more than 5 ms to cross the  $\Delta R$  and  $\Delta X$  band. Any of the zones (Z1/Z1X, Z2, Z3, Zp, Zq or Z4) can be selectively blocked. Four separate elements can be set to override the power swing blocking in case of major faults. (Delta method is used in phase selection) The relay can differentiate a stable power swing from out of step conditions, by monitoring the sign of the resistance.

### SWITCH-ON-TO-FAULT (SOTF) / TRIP-ON-RECLOSE (TOR)

The Switch-On-To-Fault and Trip On Reclose protection offers fast fault clearance following manual or auto-reclosing of circuit breakers respectively.

### CHANNEL-AIDED SCHEME LOGIC

The relay is provided with a comprehensive selection of IEC and ANSI/IEEE compatible channel-aided schemes.

- Permissive Under reach Protection, Accelerating Zone 2 (PUP Z2),
- Permissive Under reach Protection, Tripping via Forward Start (PUP forward),
- Permissive Overreach Protection with Overreaching Zone 1 (POP Z1),
- Permissive Scheme Unblocking logic, (Loss of Guard, Loss of Carrier)
- Blocking Overreach Protection with, Overreaching zone 2 (BOP Z2),
- Blocking Overreach Protection with, Overreaching zone 1 (BOP Z1),
- Weak Infeed and Echo logic.

Current reversal guard logic is available to prevent tripping of a healthy line in double circuit lines.

### CHANNEL-AIDED DIRECTIONAL EARTH FAULT (AIDED DEF)

Channel aided directional earth fault protection operates in co-ordination with one or two remote end relays. The Aided DEF protection is able to trip single or three-pole using permissive or blocking scheme logic. The transmission channels may be the same as those used by the distance protection or may be independent. The directionality of the earth fault elements is provided by either zero sequence or negative sequence polarization.

### InterMiCOM (Optional)

InterMiCOM allows high performance permissive and blocking type unit protection to be configured, plus transfer of any digital status information between line ends. Intertripping is supported too, with channel health monitoring and cyclic redundancy checks (CRC) on the received data for maximum message security.

InterMiCOM provides eight end-end signals, assignable to any function within a MiCOM relay's programmable logic. Default failsafe states can be set in case of channel outage.

### BACK-UP / TIME DELAYED PROTECTION

- Phase overcurrent: Four independent stages of phase overcurrent protection with two stages settable as directional and IDMT are available. Nine IEC/IEEE IDMT curves are provided to choose from.
- Earth fault: Four stand-by earth fault elements, all can be set directional and either DT or IDMT with an option of timer hold on reset. Both elements can be enabled at the same time.
- Voltage: Two independent stages of over and under voltage protection are provided. One of them can be configured to operate with inverse characteristics.
- The broken conductor protection provided detects unbalanced conditions caused by broken conductors, maloperation of single phase of switchgear or by other single phasing conditions.

### VT / CVT SUPERVISION (VTS / CVTS)

Voltage transformer supervision is provided to detect loss of one, two or three phases of the VT signal, providing indication and inhibition of voltage dependent protection elements. An opto-input may also be configured to initiate the voltage transformer supervision alarm and blocking when used with MCBs or other external forms of voltage transformer supervision. A separate capacitive voltage transformer supervision element is also provided to detect a voltage error due to a capacitor short-circuited in a CVT. The relay detects a permanent small zero sequence voltage and gives an alarm (adjustable timer).

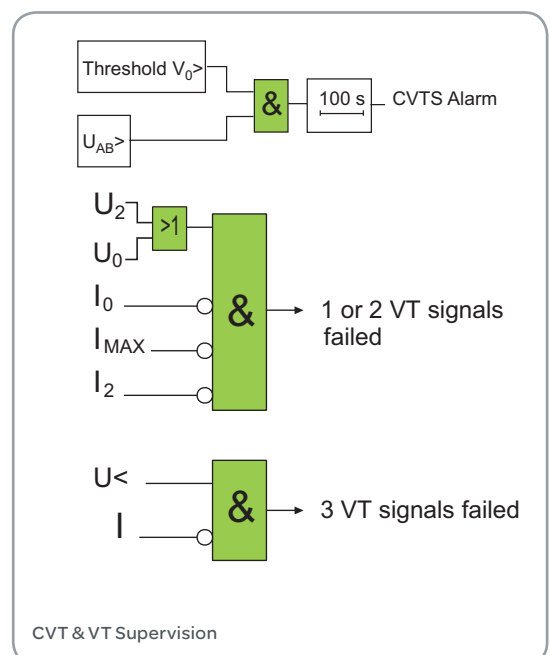

### THERMAL OVERLOAD

A thermal replica (single or dual characteristic) provides alarm and trip stages, to warn and protect in the event of prolonged circuit overloading.

### TRIP CIRCUIT SUPERVISION

The relay supervises the trip circuit in both breaker open and closed states using dedicated programmable scheme logic.

### CURRENT TRANSFORMER SUPERVISION (CTS)

Current transformer supervision is provided to detect loss of phase CT signals and inhibit the operation of current dependent protection elements.

This is achieved by detecting the presence of residual current in the absence of residual voltage.

### CIRCUIT BREAKER FAILURE PROTECTION (LBB)

Circuit breaker failure protection can be used for backtripping upstream circuit breakers, and /or for retripping via a second breaker trip coil when a local breaker failure is detected. The circuit breaker failure logic may also be initiated externally from other protection devices if required.

### AUTORECLOSE WITH CHECK SYNCHRONISING

The P441 provides three pole multi-shot (upto 4 shots) autoreclose with optional check synchronising. The P442 and P444 provide one and three pole multishot (up to 4 shots) autoreclose with optional synchronism check. For both models, the user may select a single, two, three or four shot autoreclose cycle, with independently settable dead times and reclaim time. The check synchronising function offers independent settings for manual closing and autoreclosing.

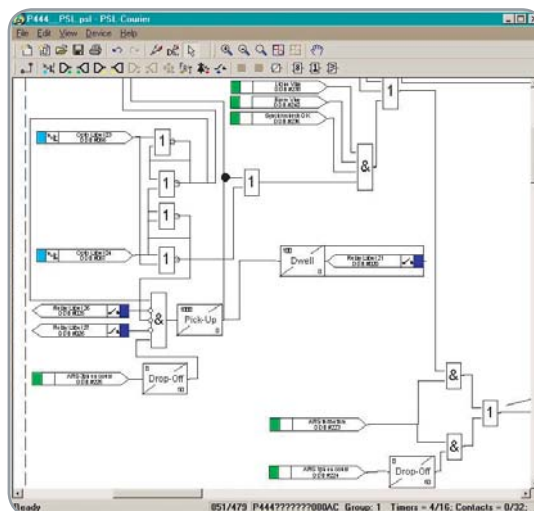

Programmable scheme logic (MiCOM S1 Studio- PSL Editor)

### PROGRAMMABLE SCHEME LOGIC

Programmable scheme logic (PSL) allows the user to customize the protection and control functions. It is also used to programme the functionality of the optically isolated inputs, relay outputs, LED indications, InterMiCOM (control input) and virtual input/output using GOOSE. The programmable scheme logic comprises of gate logic and general purpose timers. The gate logic includes OR, AND and majority gate functions, with the ability to invert the inputs and outputs, and provide feedback. The programmable scheme logic is configured using the graphical MiCOM S1 Studio PC based support software.

### FAULT LOCATION

A fault location algorithm, immune to fault resistance and load current, provides distance to fault in miles, kilometres, ohms or percentage of line. A mutual compensation feature is provided to eliminate the effect of zero sequence mutual coupling from parallel lines.

## MEASUREMENT AND RECORDING FACILITIES

A wide range of information can be displayed and stored in P441, P442 & P444 relays. All events, fault and disturbance records are time tagged to a resolution of 1ms using an internal real time clock. An optional IRIG-B port is also available for accurate time synchronisation.

A lithium battery provides a back-up for the real time clock and all records in the event of supply failure. This battery is supervised and easily replaced from the front of the relay.

The measurements provided, which may be viewed in primary or secondary values, can be accessed by the back-lit liquid crystal display, or the communications ports. A wide range of instantaneous and derived parameters are available. Phase notation is user definable using the MiCOM S1 Studio text editor.

Up to 500 time-tagged event records are stored, and can be extracted using the communication ports or viewed on the front panel display.

Records of the last 5 faults are stored. The information provided in the fault record includes:

- Indication of faulted phase
- Protection operation
- Active setting group
- Fault location
- Relay and CB operating time
- Currents, voltages and frequency

## CB Condition Monitoring

The circuit breaker condition monitoring features include:

- Monitoring the number of breaker trip operations per phase
- Recording the sum of the broken current quantity  $\sum I^x$   $1.0 < x < 2.0$
- Monitoring the breaker operating time
- Monitoring the number of breaker operations within a predetermined period.

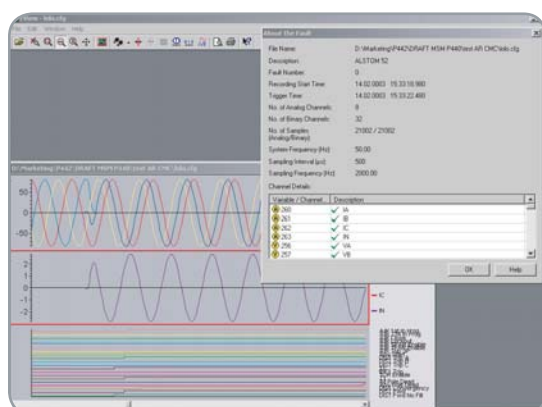

## DIAGNOSTICS

Automatic tests performed including power-on diagnostics and continuous self-monitoring ensures a high degree of reliability.

The results of the self-test functions are stored in battery backed memory. Test features available on the user interface provide examination of input quantities, states of the digital inputs and relay outputs. A local monitor port provides digital outputs, selected from a prescribed list of signals, including the status of protection elements. These test signals can also be viewed using the communication ports and front panel user interface.



### DEVICE TRACK RECORD

- **PXLN 300** relays sold from 1991 to 1999.
- **EPAC** launched in 1995 & sold 6 000 units.
- First **MiCOM P440** launched in 1999. 15 000 relays sold.
- **Phase II hardware** in 2004.
- Launch of **IEC 61850-9-2 LE** in 2005 (pilot projects) and **IEC61850-9-1** in 2006

## HARDWARE

All models include:

- A back-lit liquid crystal display (3 lines)
- 12 LEDs (8 programmable)
- An optional IRIG-B port (not P441)
- An RS232 port & an RS485 port
- An optional second RS232 / RS485 / K-Bus port (not P441)
- A download/monitor port
- A battery (supervised)
- N/O and N/C watchdog contacts
- Supervised +48V field voltage
- 1A/5A dual rated CTs
- IEC 61850-9.2 LE fibre optic input for non-conventional instrument transformers, or merging units
- Optional Redundant Ethernet ports (IEC 61850-8-1): Px4x devices can be enhanced with an optional redundant Ethernet board. The redundancy is managed by the market's fastest recovery time protocols: Self Healing Protocol and Dual Homing Protocol allowing bumpless redundancy. Furthermore, the RSTP (Rapid Spanning Tree) protocol is also available. The redundant Ethernet board supports either modulated or demodulated IRIG-B and the SNTP protocol for time synchronization. The redundant Ethernet board also has a watchdog relay contact to set alarms in case of a failure.

The opto-inputs, relay outputs and 8 of the LEDs are preconfigured as a default, but can be changed by the user. The universal voltage range opto inputs (from 24 to 250V dc) are independent and may be powered (if necessary) from the 48V field voltage available from the relay. The relay outputs may be configured as latching or self-reset.

All CT connections have in-built shorting.

## Schneider Electric Industries SAS

35, rue Joseph Monier  
CS 30323  
F - 92506 Rueil Malmaison Cedex (France)  
Tel.: +33 (0) 1 41 29 70 00  
RCS Nanterre 954 503 439  
Capital social 896 313 776 €  
www.schneider-electric.com

As standards, specifications and designs change from time to time, please ask for confirmation of the information given in this publication.

Design: Schneider Electric Industries SAS - Sonovision  
Photos: Schneider Electric Industries SAS  
Printed: Altavia Connexion - Made in France

