

MiCOM P14x

Feeder Management Relays



P141, P142 in 40TE



P143 in 60TE

MiCOM P14x feeder management relays provide an integrated solution for the complete protection, control and monitoring of overhead lines and underground cables from distribution to transmission voltage levels.

The wide range of auxiliary functions provides the user with sufficient information to efficiently maintain the power system and its components including circuit breakers, CTs, VTs, etc.

A customizable, friendly, multi-lingual user interface and programmable graphical scheme logic allows for simple and flexible applications on any network.

With optional High Speed - High Break contacts, the high break performance ensures no burn-out of contacts during normal operation or situations such as breaker failure, or defective CB auxiliary contacts.

The need for external electromechanical trip relays can be reduced/removed by transferring the high rating and durability duties into the MiCOM device thus giving further application and cost benefits.

Connecting the relay to virtually any kind of Substation Automation System or SCADA is made possible by the wide range of updated communication protocols, including IEC 61850. A range of hardware interfaces are available for easy integration into any new or legacy system.



CUSTOMER BENEFITS

- 1A & 5A in same relay
- Wide auxiliary supply voltage range
- Option of multiple communication protocol and interfaces, including IEC 61850
- User customisable menu text

APPLICATION

The MiCOM P14x range is suitable for all applications where overcurrent protection is required. It is suitable for solidly earthed, impedance earthed, Petersen coil earthed and isolated systems.

First application shows a parallel transformer protection where the P141 replaces many of the discrete protection elements normally associated with the LV side of the transformer. The protection includes nondirectional and directional phase overcurrent and earth fault, restricted earth fault and circuit breaker failure protection. The second application shows a P143 protecting a plain feeder using phase overcurrent, sensitive earth fault, negative sequence overcurrent, thermal protection and breaker failure protection. The integral autorecloser with check synchronising can be configured to grade with downstream reclosers.

ANSI	IEC 61850	Features	P141	P142	P143
50/51/67	OcpPTOC/RDIR	Directional / non-directional, instantaneous / time delayed phase overcurrent (6 stage)	•	•	•
50N/51N/67N	EfdPTOC/EfmPTOC	Directional / non-directional, instantaneous / time delayed, measured earth fault (4 stage)	•	•	•
67N	SenEftPTOC	Sensitive directional earthfault (SEF/ $I \cos\phi I \sin\phi$) (4 stage)	•	•	•
67W	SenEftPTOC	Wattmetric earthfault	•	•	•
YN		Neutral admittance protection	•	•	•
64	SenRefPDIF	Restricted earthfault	•	•	•
		Blocked overcurrent	•	•	•
		Selective overcurrent	•	•	•
		Cold load pick-up	•	•	•
51V		Voltage controlled overcurrent	•	•	•
46	NgcPTOC	Negative sequence overcurrent	•	•	•
49	ThmPTTR	RMS Thermal overload (single / dual time constant)	•	•	•
37P / 37N		Phase and neutral undercurrent	•	•	•
27	VtpPhsPTUV	Under voltage (2 stage)	•	•	•
59	VtpPhsPTOV	Over voltage (2 stage)	•	•	•
59N	VtpResPTOV	Residual over voltage (Neutral displacement) (2 stage)	•	•	•
47	NgvPTOV	Negative sequence overvoltage	•	•	•
81U	PTUF	Under frequency (9 stage) - Advanced	•	•	•
81O	PTOF	Over frequency (9 stage) - Advanced	•	•	•
81R	PFRC	Rate of Change of Freq. Prot. (9 stage) - Advanced	•	•	•
81RF		Frequency supervised rate of change of frequency (9 stage) - Advanced	•	•	•
81RAV		Average rate of change of frequency (9 stage) - Advanced	•	•	•
		Freq. based load restoration (9 stage) - Advanced	•	•	•
		Rate of change of voltage protection (2 stage)	•	•	•
BC		Broken conductor (open jumper)	•	•	•
50BF	RBRF	Circuit breaker failure	•	•	•
VTS		Voltage transformer supervision(1, 2 & 3 phase fuse failure detection)	•	•	•
CTS		Current transformer supervision	•	•	•
49SR		Silicon rectifier overload protection	•	•	•
79	RREC	4 shot three pole auto reclose	-	•	•
25	RSYN	Check synchronising	-	-	•
	2nd Harm Block	2nd Harmonic Blocking	•	•	•
32R/32L/32O		Phase segregated power	•	•	•
		Sensitive power	•	•	•
	OptGGIO	Digital inputs (maximum) *	8	16	32
	RlyGGIO	Output relays (maximum) (Hi Break - Hi speed option available)*	8	15	32
		Front communication port (RS232)	•	•	•
		Rear communication port (RS485/Optic/Ethernet) *	•	•	•
		Second rear communication port (RS232/RS485) *	Option	Option	Option
		Time synchronisation port (IRIG B modulated/unmodulated)*	Option	Option	Option
		InterMiCOM teleprotection for direct relay - relay communication EIA(RS) 232 for MODEM links upto 19.2kbit/sec	Option	Option	Option

* It may not be possible to get all in one particular model, refer data sheet for model selection

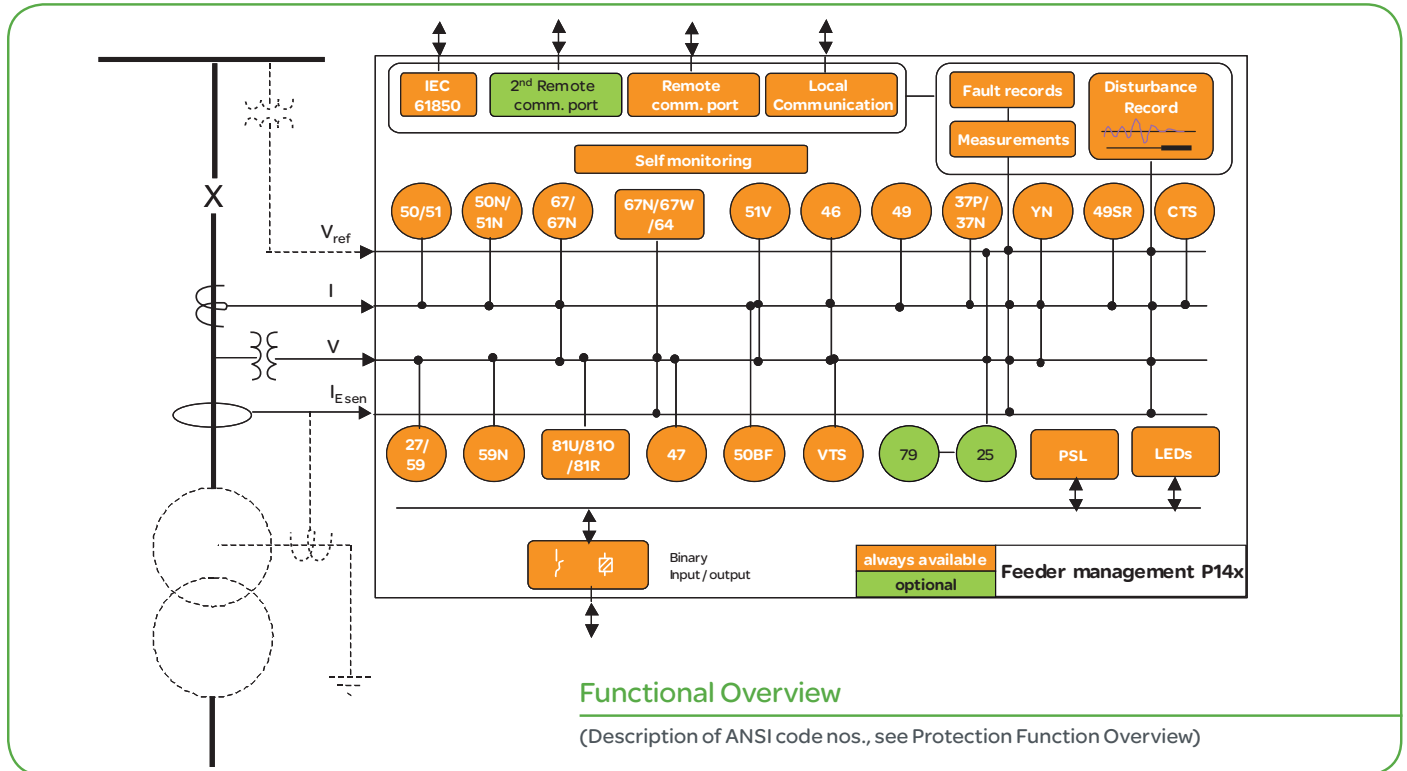

MANAGEMENT FUNCTIONS

In addition to the wide range of protection functions listed in the table, all relays in the P14x range are provided with the following measurement, control, monitoring, post fault analysis and self-diagnostic functions.

- Measurement of all instantaneous & integrated values
- Circuit breaker control, status & condition monitoring.
- Trip circuit and coil supervision
- 4 alternative setting groups

- Control inputs
- Fault locator
- Programmable scheme logic
- Programmable allocation of digital inputs and outputs
- Sequence of event recording
- Comprehensive disturbance recording (waveform capture)
- User configurable LEDs
- Local and remote communication ports
- Multiple communication protocol and interface options
- Time synchronisation
- Fully customisable menu texts
- Multi level password protection
- Power-up diagnostics and continuous selfmonitoring of relay
- User friendly setting and analysis software
- Read Only Mode
- Enhanced opto input time stamping
- Enhanced Check Sync. feature

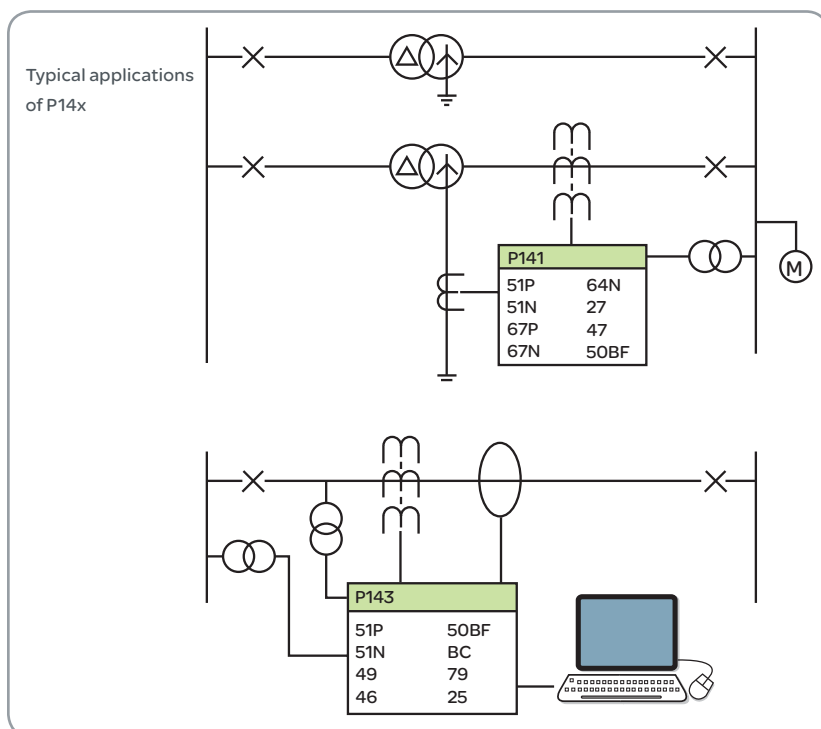

Your search for a single box feeder management relay ends with MiCOM P14x

Phase Overcurrent

Six independent stages are available for each phase overcurrent element. Each stage may be selected as non-directional or directional (forward/ reverse). All stages have definite time delayed characteristics, three of the stages may also be independently set to one of ten IDMT curves (IEC and IEEE).

The IDMT stages have a programmable reset timer for grading electro-mechanical, to reduce autoreclose dead times and to reduce clearance times where intermittent faults occur.

The phase fault directional elements are internally polarised by quadrature phase-phase voltages, and will make a correct directional decision down to:

- 0.5V (Vn = 100 - 120V) or
- 2.0V (Vn = 380 - 480V).

A synchronous polarising signal is maintained for 3.2s after voltage collapse to ensure that the instantaneous and time delayed overcurrent elements operate correctly for close-up three phase faults.

Standard Earth Fault

There are two standard earth fault elements, each with four independent stages.

- The first element operates from measured quantities:
 - Earth fault current which is directly measured using a separate CT, or
 - Residual connection of the three line CTs
- The second standard earth fault element operates from a residual current that is derived internally from the summation of the three phase currents.

All earth fault elements have the same directionality and IDMT characteristics as the phase overcurrent element. Both earth fault elements may be enabled at the same time providing directional earth fault protection and back-up standby earth fault protection in the same device. The directionality of the earth fault elements is provided by either residual voltage or negative sequence voltage.

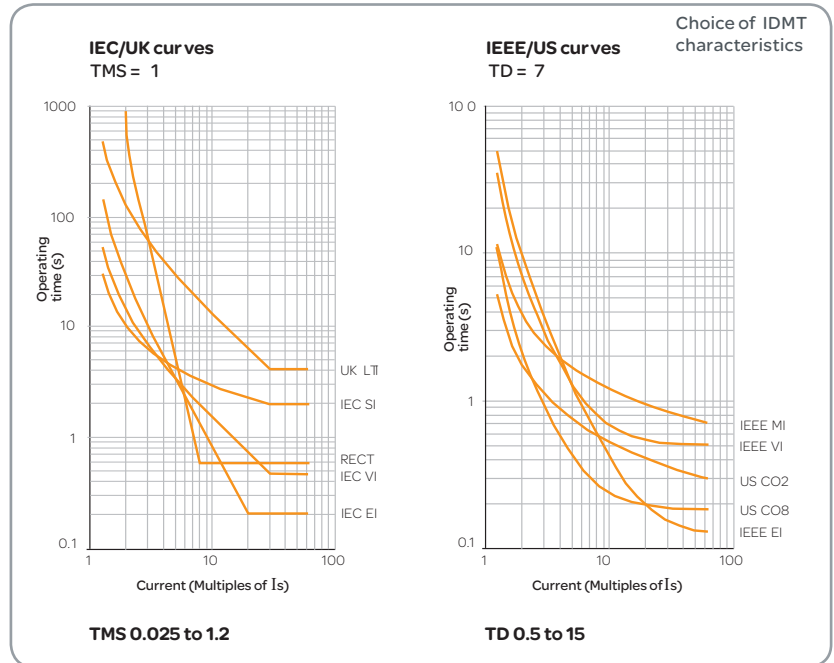

Sensitive Earth Fault

A core balance CT should be used to drive the sensitive earth fault function. The directionality of the sensitive earth fault element is provided by the residual voltage.

Wattmetric

As an alternative to the directional earthfault characteristic a directional $I \cos \phi$ characteristic can be used for Petersen coil earth fault protection using the sensitive earth fault input. A directional $I \sin \phi$ characteristic is also available for protection of insulated feeders.

Blocked Over Current

Each stage of overcurrent and earth fault protection can be blocked by an optically isolated input. This enables overcurrent and earth fault protection to integrate into a blocked overcurrent busbar protection scheme.

Cold Load Pick-Up Logic

Cold load pick-up temporarily raises the overcurrent settings following closure of the circuit breaker, allowing the protection settings to be set closer to the load profile.

Restricted Earth Fault

The restricted earth fault protection provided for protection of transformer winding against earth faults may be configured as either high impedance or low impedance biased differential.

 Features carefully designed to protect any type of system

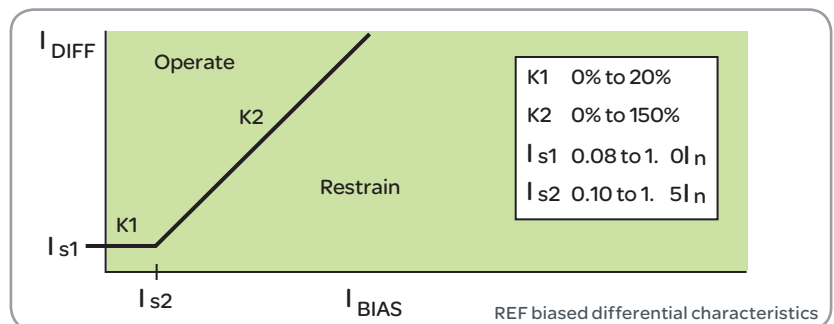

2nd Harmonic Blocking

The 2nd Harmonic Blocking detects high inrush current inflows that occur when transformers or machines are connected. The function will block the Phase over current, Earth fault, Sensitive Earth fault and Negative sequence over current.

Voltage Controlled Overcurrent

Voltage controlled overcurrent provides backup protection for remote phase faults whilst remaining insensitive to load.

Negative Sequence Overcurrent

Negative sequence overcurrent protection can be set as either non-directional or directional (forward/reverse), and can operate for remote phase-phase and phase earth faults even with delta-star transformers present.

RMS Thermal Overload

Thermal overload protection provides both alarm and trip stages. The thermal element may be set with either a single time constant characteristic for the protection of cables or dry transformers, or a dual time constant characteristic to protect oil filled transformers. In the event of loss of auxiliary supply, the thermal state is stored in non-volatile memory.

Under/Overvoltage & Rate of Change of Voltage

Under/over voltage protection may be configured to operate from either phase-phase or phase-neutral quantities. Two independent stages with definite time elements are available, one of the stages can also be configured to an inverse characteristic. Two stages of rate of change of voltage protection elements are also available, which are independently settable.

Residual Overvoltage

Residual overvoltage protection is available for detecting earth faults in high impedance earthed or isolated systems. The neutral voltage is derived from the three phase voltage inputs.

Two independent measuring elements with definite time characteristics are available, one of the elements can also be configured to have an inverse characteristic.

Frequency

Nine stages each of over frequency, under frequency, rate of change of frequency, frequency supervised rate of change of frequency, average rate of change of frequency, frequency based load shedding during severe system disturbances.

Broken Conductor

The broken conductor protection detects unbalanced conditions caused by broken conductors, maloperation of single phase of switchgear or by single phasing conditions. It operates on the ratio of I_2 to I_1 .

Phase Segregated Power

Two stages of power protection are provided and each stage can be independently configured to operate as Over Power or Under Power and Forward or Reverse direction.

The relays provide a standard 3 phase power protection element and also a single phase power protection element.

Sensitive Power

Two stages of sensitive power protection are provided and these can be independently selected as reverse power, over power, low forward power or disabled depending upon the operating condition.

Voltage Transformer Supervision

Voltage transformer supervision is provided to detect loss of one, two or three VT signals, providing indication and inhibition of voltage dependent protection elements. An optically isolated input may also be configured to initiate the voltage transformer supervision alarm and blocking when used with MCBs or other external forms of voltage transformer supervision.

Current Transformer Supervision

Current transformer supervision is provided to detect loss of phase CT signals and inhibit the operation of current dependent protection elements.

Programmable Scheme Logic

Programmable scheme logic allows the user to customize the protection and control functions. It is also used to programme the functionality of the optically isolated inputs, relay outputs and LED indications. The programmable scheme logic comprises of gate logic and general purpose timers. The gate logic includes OR, AND and majority gate functions, with the ability to invert the inputs and outputs, and provide feedback.

The programmable scheme logic is configured using the graphical MiCOM S1 Studio PC based support software.

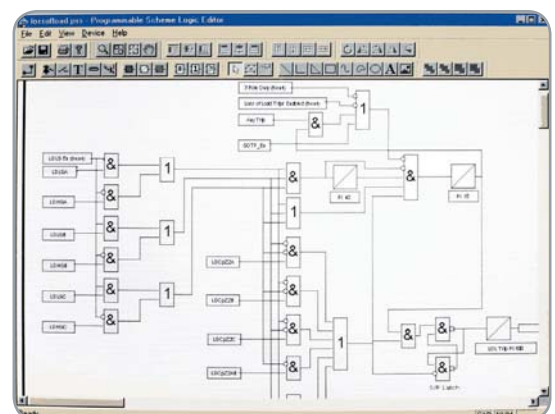

Programmable scheme logic editor (MiCOM S1 Studio)

Circuit Breaker Failure Protection

Two stage circuit breaker failure protection may be used for tripping upstream circuit breakers and re-tripping of the local circuit breaker if required.

The circuit breaker failure logic may also be initiated externally from other protection devices if required.

Circuit Breaker Control

Circuit breaker control is available from the front panel user interface, optically isolated inputs and remotely via the substation communications.

Autoreclose with Check Synchronising

The P142 and P143 provide three-pole multishot autoreclose. The user may select a single, two, three or four shot autoreclose cycle, with independently settable dead times and reclaim time. Autoreclose can be initiated from the internal protection elements or from external protection via an opto input.

Advanced features include live line working and sequence coordination (co-ordination with downstream reclosing equipment).

The P143 also includes check synchronisation.

MEASUREMENT AND RECORDING FACILITIES

The P14x series is capable of measuring and storing the values of a wide range of quantities.

All events, fault and disturbance records are time tagged to a resolution of 1ms using an internal real time clock. An optional IRIG-B port is also provided for accurate time synchronization. A lithium battery provides backup for the real time clock and all records in the event of auxiliary supply failure. This battery is supervised and easily replaced from the front of the relay.

Measurements

The measurements provided, which may be viewed in primary or secondary values, can be accessed by the back-lit liquid crystal display, or the communications ports. A wide range of instantaneous and integrated parameters are available. The list includes measured signals like phase currents and voltages and computed signals like Power, frequency, energy, etc. Phase currents and phase to neutral voltages are available in true rms and fundamental quantities.

Phase notation is user definable using the MiCOM S1 text editor.

Fault Location

A fault location algorithm provides distance to fault in miles, kilometres, ohms or percentage of line length

Event Records

Up to 512 time-tagged event records are stored in battery backed memory, and can be extracted using the communication ports or viewed on the front panel display.

Disturbance Records

The internal disturbance recorder has 8 analogue channels, 32 digital and 1 time channel.

Approximately 50 records of 0.5 s duration can be stored. All channels and the trigger source are user configurable. Disturbance records can be extracted from the relay via the remote communications and saved in the COMTRADE format. These records may be examined using MiCOM S1 Studio or any suitable software program.

Fault Records

Records of the last 5 faults are stored in battery backed memory. The information provided in the fault record includes:

- Indication of faulted phase
- Protection operation
- Active setting group
- Date and time
- Fault location
- Relay and CB operating time
- Currents, voltages and frequency

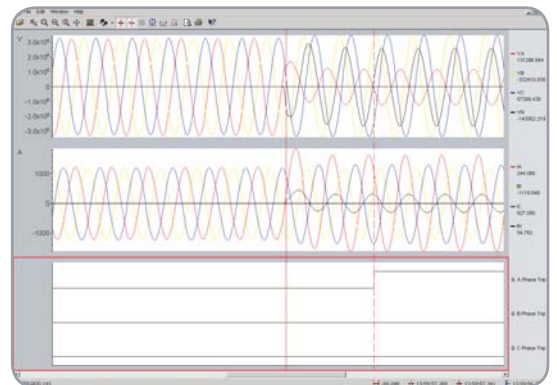

Disturbance record viewed in MiCOM S1 Studio

SUPERVISION & MONITORING

Trip Circuit Supervision

Supervision of the trip circuit in both circuit breaker open and closed states can be realised using the optically isolated inputs and programmable scheme logic.

Circuit Breaker Condition Monitoring

The circuit breaker condition monitoring features include:

- Monitoring the number of breaker trip operations
- Recording the sum of the broken current quantity $\sum I^x$, $1, 0 \leq x \leq 2, 0$
- Monitoring the breaker operating time
- Fault frequency counter

LOCAL AND REMOTE COMMUNICATIONS

Two communication ports are available as standard; a rear port providing remote communications and a front port providing local communications.

The front RS232 port has been designed for use with MiCOM S1, which fully supports functions within the relay by providing the ability to programme the settings off-line, configure the programmable scheme logic, extract and view event, disturbance and fault records, view the measurement information dynamically and perform control functions.

The default remote communications are based on RS485 voltage levels. Any of the protocols listed below can be chosen at the time of ordering.

- Courier / K-bus
- Modbus
- IEC60870-5-103 (optic interface also available)
- DNP 3.0
- IEC 61850 (over 100 Mbit/s fiber/copper Ethernet)

IEC 61850 is available when the optional Ethernet port is ordered. IEC 61850 offers high-speed data exchange, peer-to-peer communication, reporting, disturbance record extraction and time synchronization.

Redundant Ethernet is available in various options (Self healing ring, RSTP and Dual homing star).

P14x has 128 virtual inputs with an improved GOOSE performance.

An optional second rear courier port is available which may be configured as RS232, RS485 or K-Bus.

Different Communication Interfaces of P14x

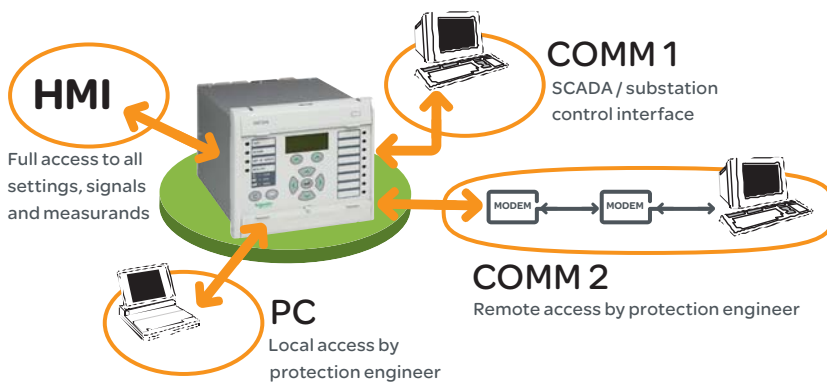

P14x provides up-to-date versatile communication options

DIAGNOSTICS

Automatic tests performed including power-on diagnostics and continuous self-monitoring ensure a high degree of reliability.

The results of the self-test functions are stored in battery backed memory. Test features available on the user interface provide examination of input quantities, states of the digital inputs and relay outputs. A local monitor port provides digital outputs, selected from a prescribed list of signals, including the status of protection elements.

These test signals can also be viewed using the communication ports and front panel user interface.

HARDWARE

All models within the MiCOM P14x series include:

- A back-lit liquid crystal display
- 12 LEDs (8 programmable)
- An optional IRIG-B port
- An RS232 port & an RS485 port
- An optional RS232/RS485/K-Bus port
- An optional ethernet port for IEC 61850 protocol
- A download/monitor port
- A battery (supervised)
- N/O and N/C watchdog contacts
- Supervised +48V field voltage
- 1A/5A dual rated CTs

Expansion cards are available to increase the number of digital inputs and outputs for the P142 and P143, and now it is possible for P141 relay to have 7 or 8 outputs depends on order. Also, depending on the relay model, up to eight High Speed-Hi Break contacts are available as an option.

This will protect against burnt contacts due to a stuck breaker or defective breaker auxiliary contact conditions.

The optically isolated inputs are independent and may be powered from the +48V field voltage.

The relay outputs may be configured as latching or self reset. All CT connections have integral shorting.



TRACK RECORD - FEEDER MANAGEMENT RELAYS

- **MODN** launched in 1998 with over 2000 units delivered
- **P14x MiCOM series** introduced in 1999. Worldwide application, with over 10000 units delivered.
- Introduction of **phase II hardware** of MiCOM P14x in 2002.
- Addition of **UCA2 protocol** and ethernet port in 2004
- Addition of **IEC 61850 protocol** in 2006

Schneider Electric Industries SAS

35, rue Joseph Monier
CS 30323
F - 92506 Rueil Malmaison Cedex (France)
Tel.: +33 (0) 1 41 29 70 00
RCS Nanterre 954 503 439
Capital social 896 313 776 €
www.schneider-electric.com

As standards, specifications and designs change from time to time, please ask for confirmation of the information given in this publication.

Design: Schneider Electric Industries SAS - Sonovision
Photos: Schneider Electric Industries SAS
Printed: Altavia Connexion - Made in France



*This document has been
printed on recycled paper.*